



AMERICAN SPECIALTIES, INC.
 441 Saw Mill River Road, NY 10701
 (914) 476.9000 • (914) 476.0688
 www.americanspecialties.com

MODEL №: 0034

ISSUED: 04/06

REVISED: 07/10

PARTITION MOUNTED DUAL TWIN HIDE-A-ROLL TOILET PAPER DISPENSER

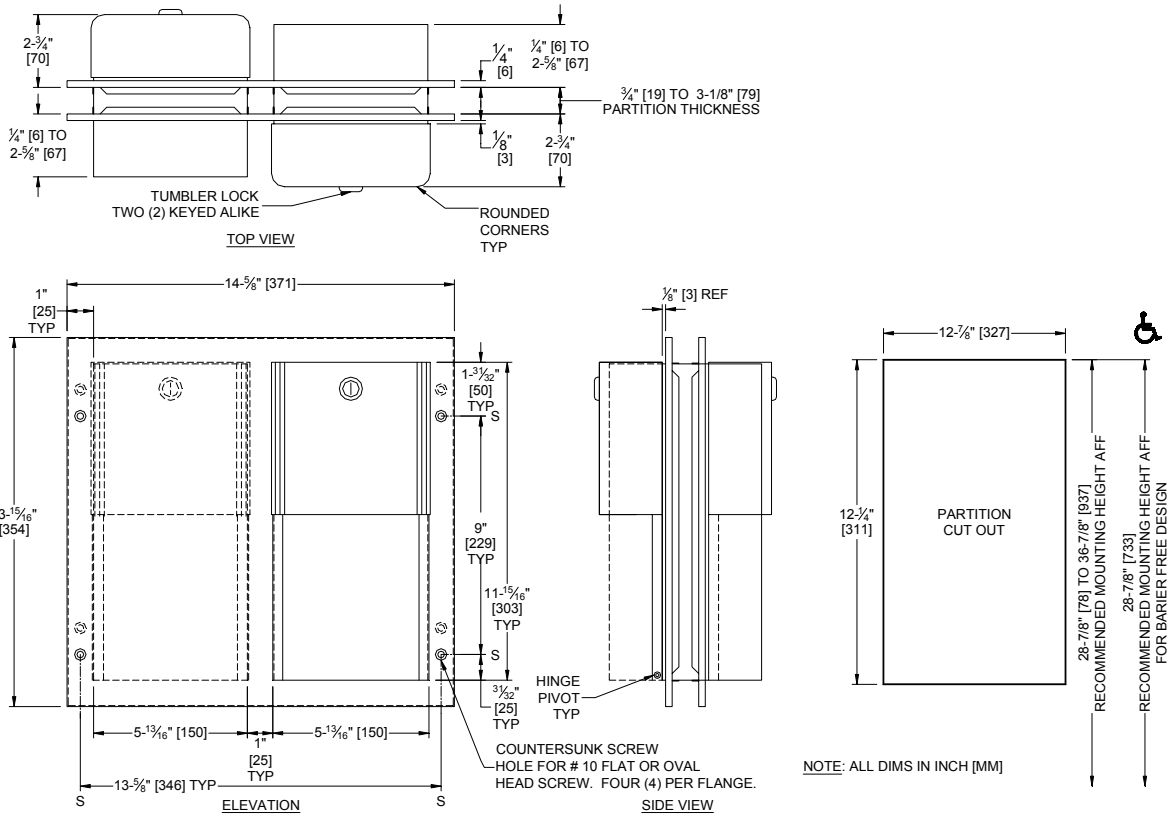

NOTE: ALL DIMS IN INCH [MM]

SPECIFICATION

Partition Mounted Dual Twin Hide-A-Roll Toilet Paper Dispenser for reduced partition projection shall hold and dispense four (4) standard or four (4) 5-1/4" diameter (Ø133) 1800 sheets paper rolls. Unit shall have doors, door frames, and dispensing mechanism guide tracks fabricated of 18 gauge type 304 stainless steel alloy 18-8. Cabinet bodies and mounting flanges shall be 22 gauge same grade. Face trim mounting flanges shall be of one-piece construction 1" (25) wide with no welded miters and shall have square 1/4" (6) returns to partition. All exposed surfaces shall be satin finish and be protected during shipment with PVC film easily removable after installation. Internal mechanism levers shall be fabricated of molded high-impact resistant plastic for smooth operation. Structural assembly of body and door components shall be of welded construction. Door hinges shall be heavy-duty stainless steel 3/16" diameter (Ø4.8) rivets. Doors shall have 3/4" (19) rounded vertical edges with all corners welded and ground smooth with no open miters and each shall be held closed with a standard cylinder tumbler lock keyed alike to other ASI washroom equipment. Cabinet shall include theft and vandal resistant rollers that shall be of molded high-impact resistant plastic with integral molded-in plated steel endpins and four (4) rollers [p/n R-004] shall be supplied.

Partition Mounted Dual Twin Hide-a-Roll Toilet Paper Dispenser for reduced partition projection shall be Model № 0034 as manufactured by American Specialties, Inc. 441 Saw Mill River Road Yonkers, New York 10701-4913

INSTALLATION

Partition mount unit through precut partition cutout (PCO) using four (4) № 10 x 3/4" (M5 x 20) Philips flat head or oval head self tapping screws (supplied) per side (eight [8] total) through mounting holes provided through fixed mounting frame and adjustable mounting frame into suitably prepared partition (by others). Mounting holes are offset 1/2" (13) from opposite side frame holes for screw clearance. Mounting flanges adjust to accommodate partition thickness in range of 3/4" (19) to 3-1/8" (79). For compliance with ADA Accessibility Guidelines install top of unit 30" (762) MAX AFF and with centerline of TP roll between 7" to 9" (178 ~ 229) from front of commode.

PCO Required is 12-7/8" W x 12-1/4" H x 3/4" to 3-1/8" Thickness (327 x 311 x 19 ~ 79)

OPERATION

Reloading instructions are printed on graphic label inside each door. Bottom roll is depleted prior to top roll automatically dropping into lower position for use. Empty rollers cannot be removed without key unlocking door. Individual two-roll dispenser is accessible from each side of partition.