



**AMERICAN SPECIALTIES, INC.**  
441 Saw Mill River Road, Yonkers, NY 10701 (914) 476-9000

MODEL No: 04406

ISSUED: 1-87

REVISED: 3-97

**DEEP RECESSED CABINET WITH SHELF, MIRROR AND PAPER TOWEL DISPENSER**

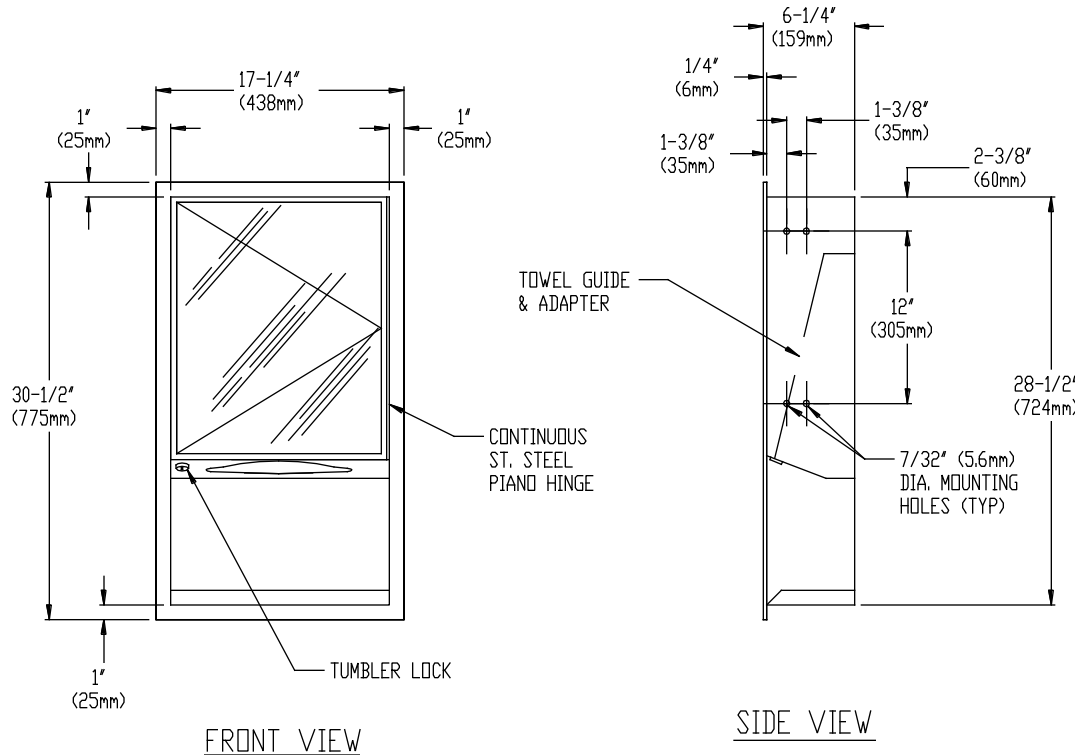

**SPECIFICATION**

Deep Recessed Cabinet with Shelf, Mirror and Paper Towel Dispenser shall hold 800 standard multi-fold or 500 standard C-fold or 1100 single fold paper towels. Cabinet, door and frame shall be fabricated of alloy 18-8 stainless steel, type 304, N<sup>o</sup>22 gauge. Towel dispensing slot shall have a fully hemmed-in rolled edge for snag-free dispensing and user safety. Door shall be attached to cabinet at side with a full length 3/16" dia. (4.8mm) stainless steel multi- staked piano hinge and shall be held closed with a tumbler lock keyed alike to other ASI Washroom Equipment. Mirror shall be fabricated of 1/4" thick plate glass, and warranted for 15 years. Face trim shall be 1" (25mm) wide formed from one piece with no mitres, welding or open seams and have 1/4" (6.4mm) square return to wall. Structural assembly of all components shall be of welded construction. All exposed surfaces shall be N<sup>o</sup> 4 satin finish and be protected during shipment with a PVC film easily removable after installation.

**Deep Recessed Cabinet with Shelf, Mirror and Paper Towel Dispenser shall be Model N<sup>o</sup> 04406 as fabricated by American Specialties, Inc. 441 Saw Mill River Road Yonkers, New York 10701-4913**

**INSTALLATION**

Unit is recessed mounted in wall using N<sup>o</sup>10 self tapping screws (supplied) through concealed mounting holes provided. For compliance with ADA Accessibility Guidelines, unit should be installed so that bottom edge of reflecting surface is no higher than 40" (1016mm) above finished floor. Note that top of RWO is 3/4" (19mm) below top of unit.

**Rough wall opening (RWO) required is 15-3/4"W x 29"H x 6-1/4" minimum D ( 400mm x 736mm x 159mm).**

**OPERATION**

Towels are self-feeding until supply is depleted. Unit may be reloaded easily by opening door/mirror assembly with a partial load in-place and will continue to feed properly. Towel supply is replenished manually on cycle determined by maintenance needs.

**OPTIONS**

See options list for descriptions of available combinations of configurations.

Accessory Specialties

AMERICAN DISPENSER

Desert Ray Products

WATROUS INC.