



AMERICAN SPECIALTIES, INC.
 441 Saw Mill River Road, Yonkers, NY 10701 (914) 476-9000
 www.americanspecialties.com

MODEL No: 04501

ISSUED: 1-87

REVISED: 9-07

RECESSED ROLL PAPER TOWEL CABINET

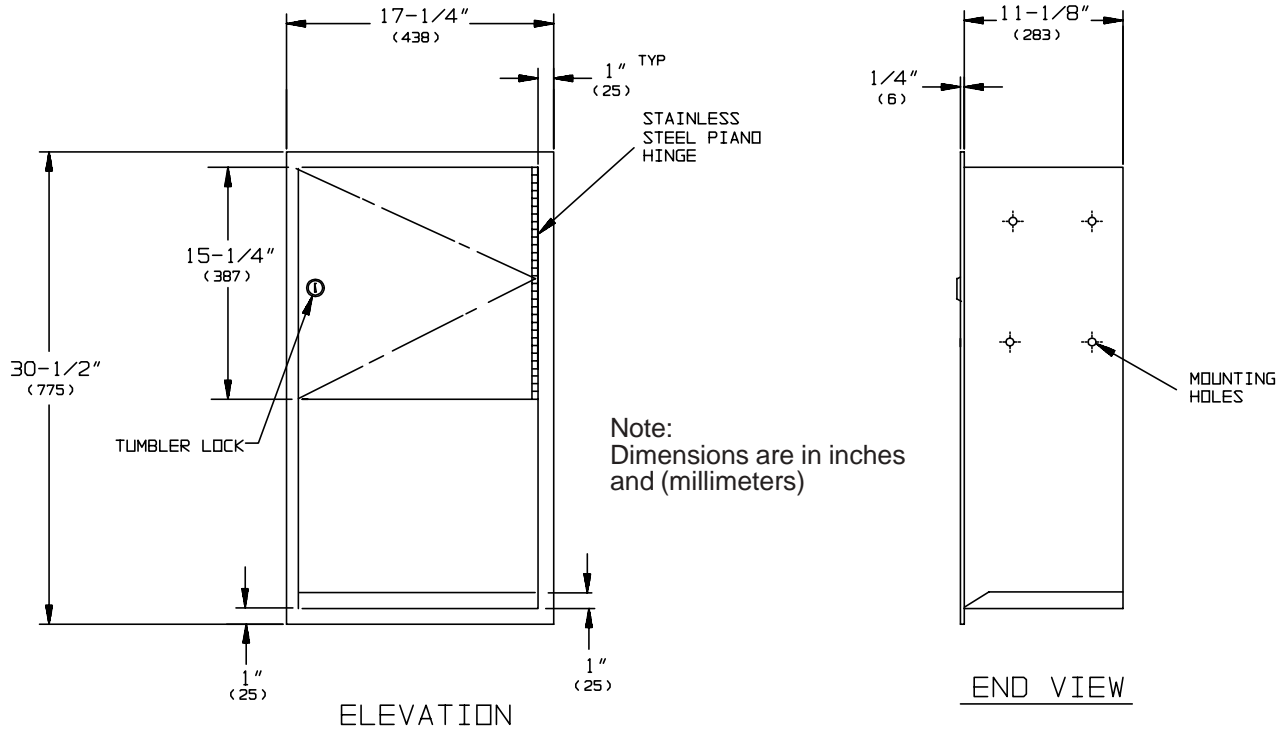

SPECIFICATION

Recessed Roll Paper Towel Cabinet shall accept one roll towel dispenser by the following other manufacturers: Crown-Zellerback, Fort Howard, Georgia Pacific, Scott Towel, TowlSaver, West Chemical Products and others of similar size and mounting requirements. Cabinet is supplied without any dispenser unit and shall accommodate a dispenser mechanism for roll paper towel furnished and installed by others. Unit door, frame and cabinet shall be fabricated of type 304 stainless steel alloy 18-8. Door shall be of single-pan construction in 18 gauge, back shall be 18 gauge, all other parts shall be 22 gauge. All exposed surfaces shall have N° 4 satin finish protected by plastic PVC film easily removed after installation. Door shall be attached to cabinet at side with a full-length 3/16" diameter (Ø4.8) stainless steel multi-staked piano hinge and be held closed with a tumbler lock keyed alike to other ASI washroom equipment. Face trim shall be 1" (25.4) wide formed from one piece with no miters, welding or open seams and have 1/4" (6.4) square return to wall. Structural assembly of all components shall be of welded construction. Cabinet shall have no exposed fastening devices or spot-welded seams.

Recessed Roll Paper Towel Cabinet shall be Model N° 04501 as manufactured by American Specialties, Inc., 441 Saw Mill River Road, Yonkers, New York 10701-4913

INSTALLATION

Install unit in wall recess using four (4) N° 10 self-tapping screws (by others) through concealed mounting holes provided. Roll towel mechanism (by others) not furnished by ASI. Installer must drill back to accept self-tapping screws in mounting pattern to match mechanism selected. Installer must also cut any cover access window or slot required to present actuating controls to user. For ADAAG compliance install unit so that any actuating control or towel dispenser slot (whichever is higher) is 48" (1219) maximum above finished floor (MAX AFF). Note that top of Rough Wall Opening (RWO) is 3/4" (19) below top of unit.

RWO required is 15-3/4" W x 29" H x 11-1/8" D (400 x740 x 283)

OPERATION

Towels are fed by owner chosen mechanism (supplied by others) until supply is depleted. Towels are loaded by opening cabinet door to access selected dispenser mechanism and by following instructions provided by others. Locked compartment prevents unauthorized access or removal.

Accessory Specialties

AMERICAN DISPENSER

Desert Ray Products

WATROUS INC.