

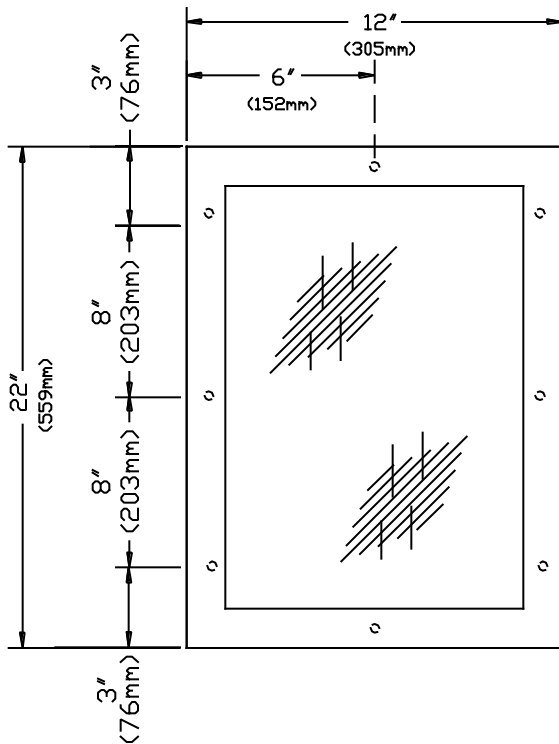

AMERICAN SPECIALTIES, INC.
441 Saw Mill River Road, Yonkers, NY 10701 (914) 476-9000

MODEL No: 100
ISSUED: 11-91
REVISED: 9-96

SECURITY FRAMED MIRROR



ELEVATION

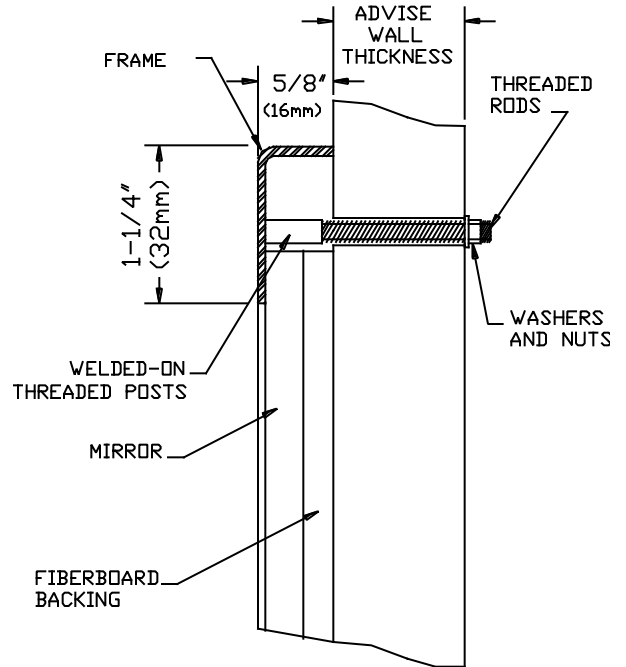

PARTIAL SECTION

SPECIFICATION

Chase Mounted Security Framed Mirror shall have frame fabricated of alloy 18-8 stainless steel, type 304, N^o 14 gauge. Structural assembly of frame components shall be of welded construction with eight (8) welded on threaded posts. All exposed surfaces shall be N^o4 satin finish. Mirror construction shall be as specified in the Glazing Options chart. Unit shall be provided with fiberboard backing. Mounting hardware shall be sized and supplied as indicated in the installation wall thickness chart.

Chase Mounted Security Framed Mirror shall be Model N^o 100-xx as fabricated by American Specialties, Inc., 441 Saw Mill River Road, Yonkers, NY 10701-4913

INSTALLATION

Unit is anchored through wall or partition using eight (8) 1/4 - 20 threaded rods, washers & nuts (supplied). For compliance with ADA Accessibility Guidelines, bottom edge of reflecting surface should be no higher than 40" (1016mm) maximum above finished floor. For proper installation hardware selection specify the wall thickness on which unit is to be mounted (indicate thickness of wall with check mark ✓ and specify length if over 8" (203mm)).

Up to 6" 152mm)	8" (203mm)	Over 8" (203mm) specify	max.	inches
-----------------	------------	-------------------------	------	--------

GLAZING OPTIONS

Specify glazing option from chart below by adding code suffix to model number (i.e. 100-14).

Suffix	Material	Finish	Image Quality
14	20 gauge type 304 stainless steel	N ^o 8 mirror polish	excellent
30	20 gauge type 430 stainless steel	bright annealed	good
31	22 gauge steel	chrome plated	excellent
13	1/4" thick tempered glass	polished mirror	excellent
17	1/4" thick Plexiglass	polished mirror	excellent

Accessory Specialties

AMERICAN DISPENSER

Desert Ray Products

WATROUS INC.