



AMERICAN SPECIALTIES, INC.

441 Saw Mill River Road, Yonkers, NY 10701 (914) 476-9000
www.americanspecialties.com

MODEL No: 1305-03081315

ISSUED: 1-87

REVISED: 8-06

TELEPHONE ACCOMMODATION WITH DIRECTORY HOLDER, BINDER AND CHAIN

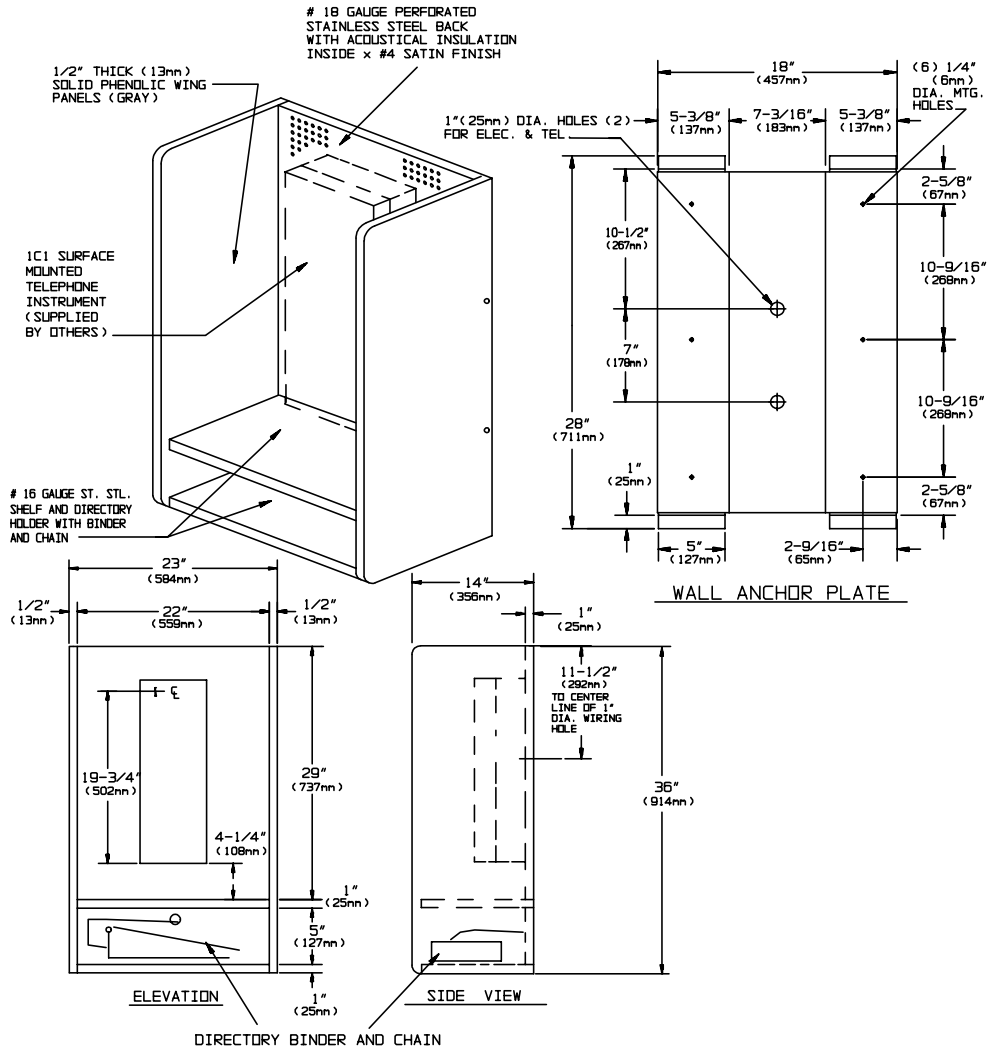

SPECIFICATION

Telephone Accommodation with Directory Holder and Binder and Chain shall have wing panels fabricated of 1/2" (13mm) thick solid Phenolic gray color with black edges (Wilsonart D381-60 is standard). Back panel of booth shall be fabricated of 18 gauge perforated stainless steel alloy 18-8 type 304 and shelf and Directory Holder Shelf shall be smooth 16 gauge, with a N° 4 satin finish on all exposed surfaces. Unit is prepared to accept standard N° 1C1 surface mounted telephone (provided by others) onto concealed mounting plate. Unit shall have wall anchor plate and mounting bracket fabricated of 18 gauge paint-lok steel, which shall have six (6) 1/4" diameter (Ø6.4mm) mounting holes, two (2) 1" diameter (Ø25.4mm) wiring holes and hole-slots and tapped holes for standard telephone mounting. Unit is provided with binder and chain for installation in directory holder compartment.

Telephone Accommodation with Directory Holder, Binder and Chain shall be Tellette Model N° 1305-03081315 as manufactured by American Specialties, Inc., 441 Saw River Road, Yonkers, NY 10701-4913

INSTALLATION

Secure wall anchor plate to finished wall through six (6) mounting holes provided. Hang assembled booth onto wall anchor plate. Telephone instrument (supplied by others) is then set onto back of unit and secured, making total assembly theft-resistant. Binder and chain are furnished by ASI and installed by others to pre-drilled attachment hole. Installer must furnish mounting hardware to suit wall construction. Suggested mounting height for general utility is 70" (1778mm) AFF to the top of unit to place coin slot at 65" (1651mm) AFF. For compliance with ADA Accessibility Guidelines side reach access mount unit 54" (1372mm) MAX AFF to the centerline of coin slot, by installing unit with top at 59" (1499) MAX AFF.

Accessory Specialties

AMERICAN DISPENSER

Desert Ray Products

WATROUS INC.