



AMERICAN SPECIALTIES, INC.

441 Saw Mill River Road, Yonkers, NY 10701 (914) 476-9000
www.americanspecialties.com

MODEL No: 1305-04C08101315

ISSUED: 1-87

REVISED: 9-06

TELEPHONE ACCOMMODATION FOR ADAAG FRONT REACH ACCESS COMPLIANCE WITH DIRECTORY HOLDER AND BINDER AND CHAIN

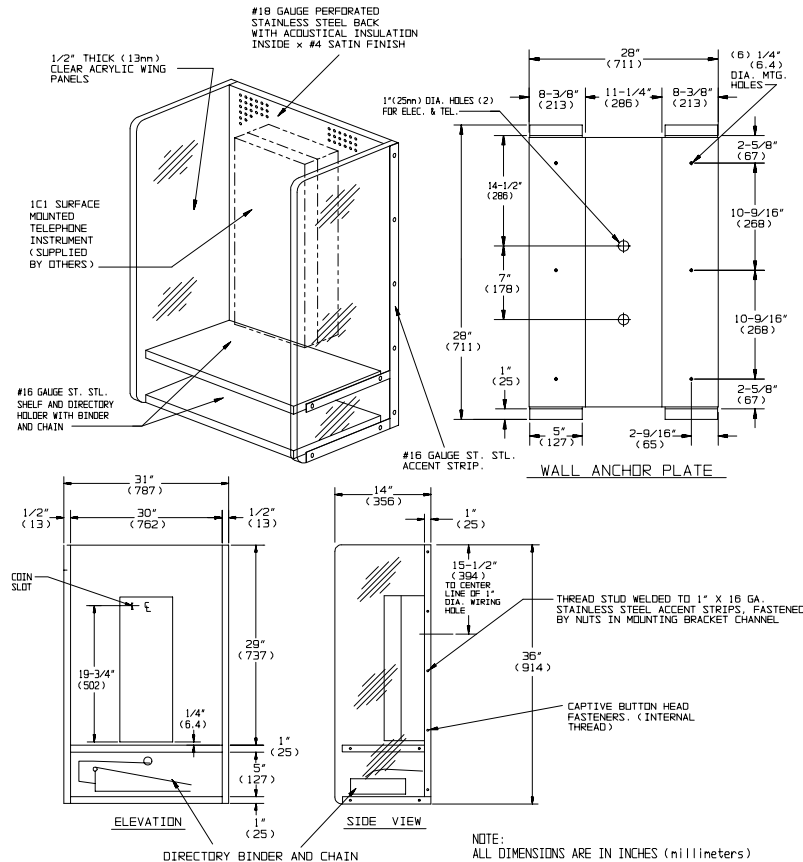

SPECIFICATION

Telephone Accommodation for ADAAG Front Reach Access Compliance with Directory Holder and Binder and Chain shall have back panel fabricated of perforated stainless steel, alloy 18-8 type 304, 18 gauge. Shelves and 1" (25.4mm) wide accent strips at each side shall be 16 gauge stainless steel. All exposed surfaces shall have a N^o 4 satin finish. Wing panels shall be 1/2" (13mm) thick clear acrylic. Unit is prepared to accept standard N^o 1C1 surface mounted telephone (provided by others) onto concealed mounting plate. Unit shall have wall anchor plate and mounting bracket fabricated of 18 gauge paint-lok steel, which shall have six (6) 1/4" diameter (Ø6.4mm) mounting holes, two (2) 1" diameter (Ø25.4mm) wiring holes and hole-slots and tapped holes for standard telephone mounting at 48" (1219mm) coin slot centerline height. Unit is provided with binder and chain for installation in directory holder compartment. For multiple bay installations [option -17-n] add 30-1/2" (775mm) to overall width for each additional telephone.

Telephone Accommodation with Acoustic Back Panel and Directory Holder for ADAAG compliance shall be Tellette Model N^o 1305-04C08101315 as manufactured by American Specialties, 441 Saw Mill River Road, Yonkers, NY 10701-4913

INSTALLATION

Secure wall anchor plate to finished wall through six (6) mounting holes provided. Hang assembled booth onto wall anchor plate. Set telephone instrument (supplied by others) onto back of unit and secure it to mounting holes provided, making total assembly theft-resistant. Installer must furnish mounting hardware to suit wall construction. Binder and chain are furnished by ASI and installed by others to pre-drilled attachment hole. **For compliance with ADA Accessibility Guidelines front reach access mount unit 44" (1118mm) MAX AFF to the coin slot centerline with top of unit at 53" (1346mm) AFF and bottom of Directory Holder at 17" (432mm) AFF.** For compliance with ADA Accessibility Guidelines side reach access mount unit 46" (1168mm) MAX AFF to the coin slot centerline, by installing unit with top at 55" (1397mm) MAX AFF. Suggested mounting height for Non-ADAAG compliant general utility is 74" (1880mm) AFF to the top of unit to place coin slot centerline at 65" (1651mm) AFF.

Accessory Specialties

AMERICAN DISPENSER

Desert Ray Products

WATROUS INC.