



**AMERICAN SPECIALTIES, INC.**  
 441 Saw Mill River Road, Yonkers, NY 10701 (914) 476-9000  
 www.americanspecialties.com

MODEL No: 1305-04C0813

ISSUED: 1-87

REVISED: 6-06

**TELEPHONE ACCOMMODATION WITH DIRECTORY HOLDER**

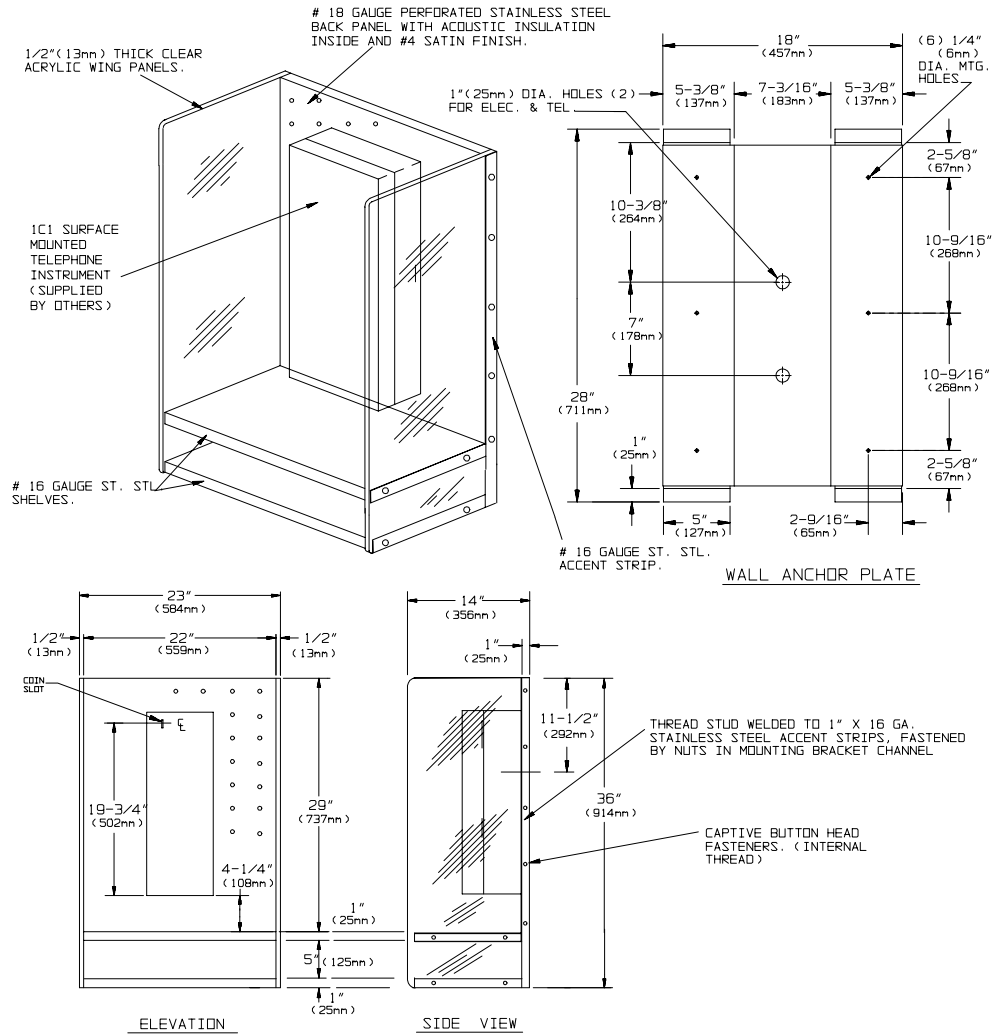

**SPECIFICATION**

Telephone Accommodation with Directory Shelf shall have back panel fabricated of 18 gauge perforated stainless steel alloy 18-8 type 304, with acoustic absorption infill. Shelves and 1" (25.4mm) wide accent strips at each side shall be 16 gauge stainless steel. Wing panels shall be 1/2" (13mm) thick clear acrylic (standard). All exposed metal surfaces shall have a N<sup>o</sup> 4 satin finish. Unit is prepared to accept standard N<sup>o</sup> 1C1 surface mounted telephone (provided by others) onto concealed mounting plate. Unit shall have wall anchor plate and mounting bracket fabricated of 18 gauge paint-lok steel, which shall have six (6) 1/4" diameter (Ø6.4mm) mounting holes, two (2) 1" diameter (Ø25.4mm) wiring holes and hole-slots and tapped holes for standard telephone mounting. For multiple installations [option -17-n] add 22-1/2" (572mm) to overall width for each additional telephone.

**Telephone Accommodation with Directory Shelf shall be Tellette Model N<sup>o</sup> 1305-04C0813 as manufactured by American Specialties, Inc., 441 Saw Mill River Road, Yonkers, NY 10701-4913**

**INSTALLATION**

Secure wall anchor plate to finished wall through six (6) mounting holes provided. Hang assembled booth onto wall anchor plate. Telephone instrument (supplied by others) is then set onto back of unit and secured, making total assembly theft-resistant. Installer must furnish mounting hardware to suit wall construction. Suggested mounting height for general utility is 70" (1778mm) maximum above finished floor (MAX AFF) to the top of unit to place coin slot at 65" (1651mm) MAX AFF. For compliance with ADA Accessibility Guidelines side reach access mount unit 54" (1372mm) MAX AFF to the centerline of coin slot. For compliance with ADA Accessibility Guidelines front reach access use Option 10 (see 1305-04C081013) and mount unit 44" (1118mm) MAX AFF to the centerline of coin slot.

Accessory Specialties

AMERICAN DISPENSER

Desert Ray Products

WATROUS INC.