



AMERICAN SPECIALTIES, INC.

441 Saw Mill River Road, Yonkers, NY 10701 (914) 476-9000
www.americanspecialties.com

MODEL No: 1350-07C

ISSUED: 1-87

REVISED: 4-06

TELEPHONE ACCOMMODATION

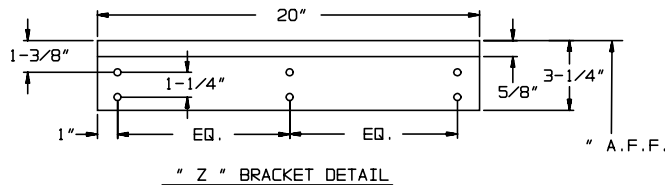
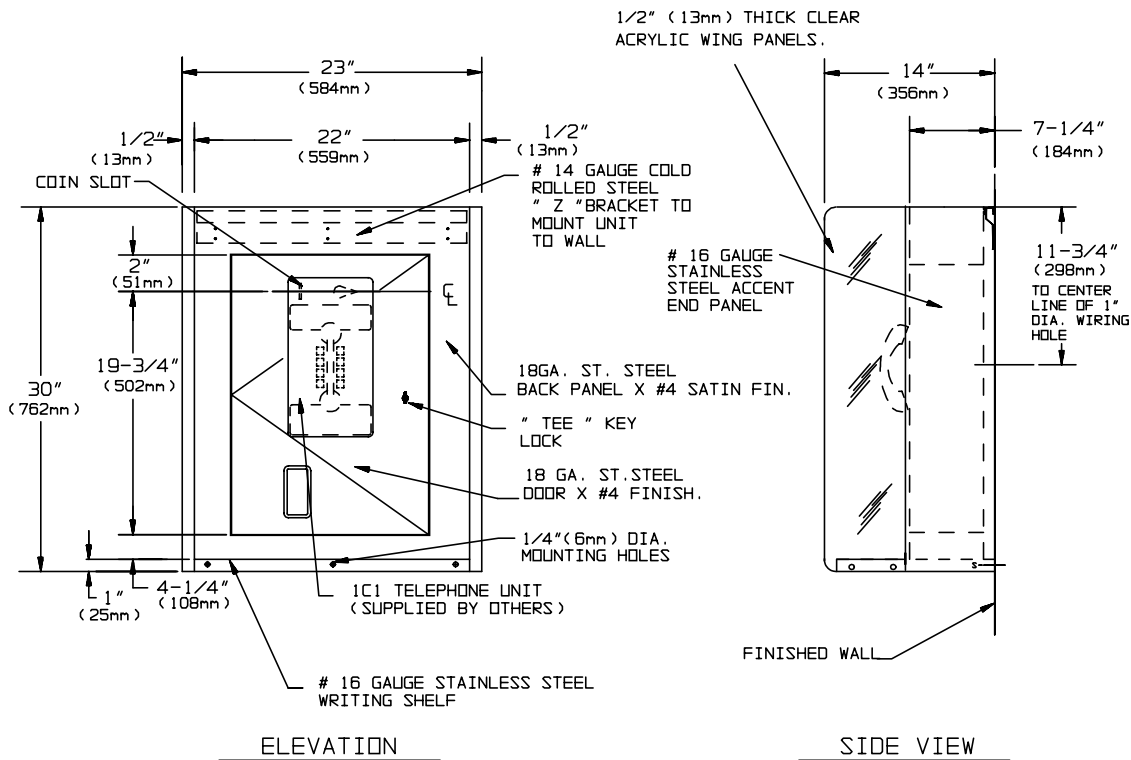

SPECIFICATION

Telephone Accommodation shall have door and back panel fabricated of 18 gauge stainless steel alloy 18-8 type 304 with a N° 4 satin finish. Wing panels shall be 1/2" (13mm) thick clear acrylic. Shelf and 1" (25.4mm) and 7" (178mm) wide accent strips and panels at each side shall be 16 gauge stainless steel with a N° 4 satin finish. Unit is prepared to accept standard N° 1C1 surface mounted telephone (provided by others) onto mounting plate behind concealed hinge door with T-key lock to provide panel phone look. Unit shall be provided with a 14 gauge cold rolled steel "Z" clip inside top for concealed mounting and three (3) 1/4" diameter (Ø6.4mm) mounting holes concealed on bottom under shelf to secure unit to wall. For multiple bay installations [option -17-n] add 22-1/2" (572mm) to overall width for each additional telephone.

Telephone Accommodation shall be Tellette Model N° 1350-07C as manufactured by American Specialties, Inc., 441 Saw Mill River Road, Yonkers, NY 10701-4913.

INSTALLATION

Secure "Z" bracket to finished wall with screws (by others) into suitable blocking or other wall reinforcements. Hang assembled booth onto wall bracket and install screws (by others) through mounting holes in rear of shelf to make unit non removable. Telephone instrument (provided by others) is then set onto back plate of unit. Screws (by others) are installed to lock instrument to back plate. Door is then secured making total assembly theft-resistant. Suggested mounting height for general utility is 70" (1778mm) maximum above finished floor (MAX AFF) to the top of unit to place coin slot at 65" (1651mm) MAX AFF. For compliance with ADA Accessibility Guidelines side reach access mount unit 54" (1372mm) MAX AFF to the centerline of coin slot. For compliance with ADA Accessibility Guidelines front reach access use Option 10 (see 1350-07C10) and mount unit 48" (1219mm) MAX AFF to the centerline of coin slot.

Accessory Specialties

AMERICAN DISPENSER

Desert Ray Products

WATROUS INC.