



# AMERICAN SPECIALTIES, INC.

441 Saw Mill River Road, Yonkers, NY 10701 (914) 476-9000  
www.americanspecialties.com

MODEL No: 1550-1017-2-MPED

ISSUED: 1-96

REVISED: 5-07

## DUAL CURVED TELEPHONE ACCOMMODATION WITH ACOUSTIC PANELS, FLUSH PANEL HOUSINGS, WRITING SHELVES AND PEDESTAL COLUMN FOR ADAAG COMPLIANCE (Pg 1/2)

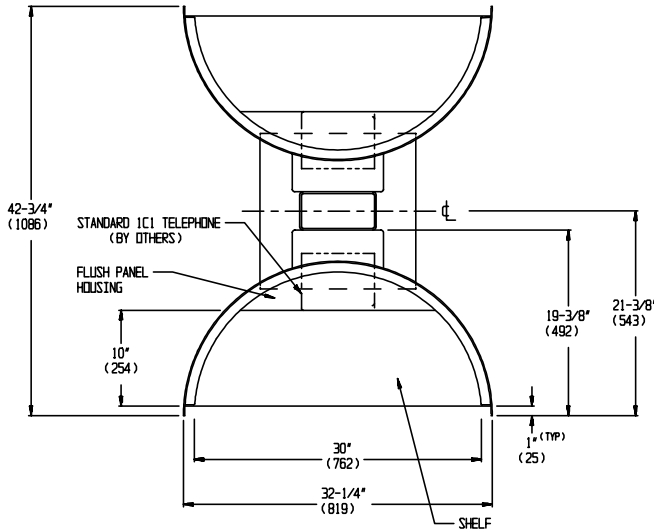

NOTE: TELEPHONE ENCLOSURES ARE THE SAME BOTH SIDES

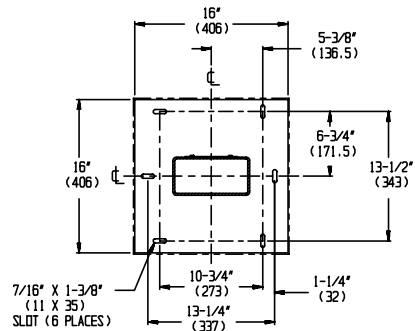

SECTION A-A  
PEDESTAL BASE LESS COVER

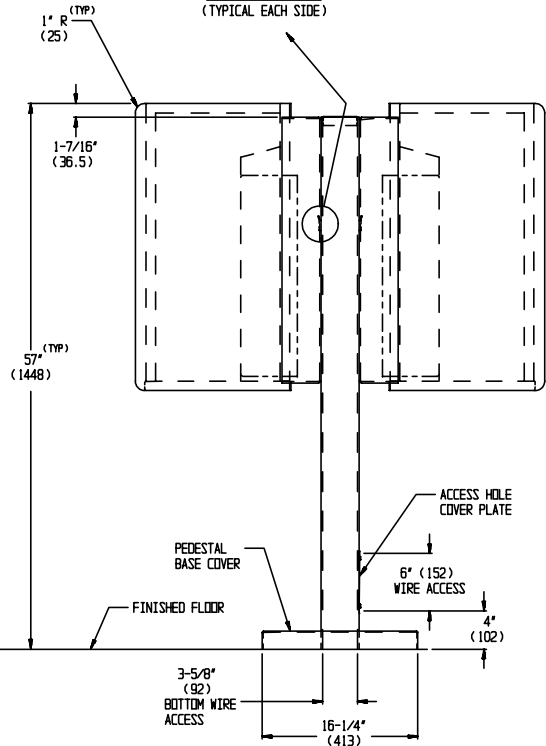
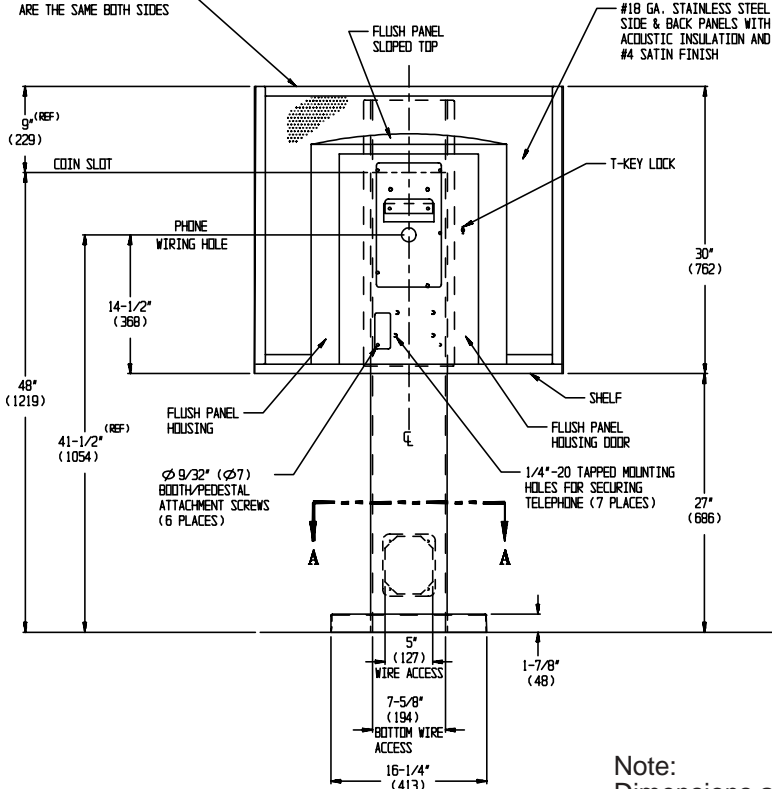
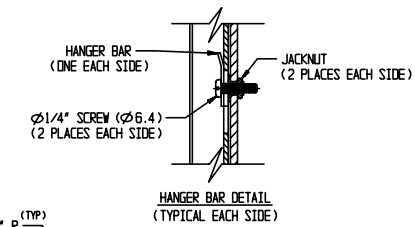

Note:  
Dimensions are in inches and (millimeters)



# AMERICAN SPECIALTIES, INC.

441 Saw Mill River Road, Yonkers, NY 10701 (914) 476-9000  
www.americanspecialties.com

MODEL No: 1550-1017-2-MPED

ISSUED: 1-96

REVISED: 5-07

## DUAL CURVED TELEPHONE ACCOMMODATION WITH ACOUSTIC PANELS, FLUSH PANEL HOUSINGS, WRITING SHELVES AND PEDESTAL COLUMN FOR ADAAG COMPLIANCE (Pg 2/2)

### SPECIFICATION

Dual Curved Telephone Accommodation with Acoustic Panels, Flush Panel Housings, Writing Shelves and Pedestal Column for ADAAG Access Compliance shall be fabricated of type 304 stainless steel alloy 18-8. Each one-piece surround shall be 1/8" (3.2) thick. Each shelf shall be 16 gauge with a removable closure plate on bottom held in place with pin-Torx® security button head screws. Each enclosure shall have an 18 gauge perforated stainless steel interior 1" (25.4) thick with acoustic insulation filler inside for sound control. Each flush panel housing and door shall be 18 gauge. All exposed surfaces shall have a N° 4 satin finish. Each unit is prepared to accept a standard N° 1C1 surface mounted telephone (provided by others) onto mounting plate, which shall have a 1-1/2" diameter (Ø38) wiring hole and seven (7) 1/4-20-UNC-2B tapped holes for telephone mounting, behind concealed hinge door with T-key lock to provide panel phone look. The dual unit is provided with a pedestal column painted black fabricated of CRS A500 with 3/16" (4.8) wall thickness and section size of 4" x 8" (102 x 203). Column is welded to 1-7/8" (48) thick fabricated base plate with (6) mounting slots for 3/8" (9.5) bolts for floor connection. Column shall have access for telephone and electric power wires coming up from bottom through cutout in base center. Column is provided with base cover plate and column side access port cover plate, both fabricated of 16 gauge alloy 18-8 stainless steel type 304 with N° 4 satin finish and held closed with N° 10-32 pin Torx® security button head screws. Top of column shall be closed.

**Dual Curved Telephone Accommodation with Acoustic panels, Flush Panel Housings, Writing Shelves and Pedestal Column for ADAAG Compliance shall be Tellette Model N° 1550-1017-2-MPED as manufactured by American Specialties Inc., 441 Saw Mill River Road, Yonkers, NY 10701-4913**

### INSTALLATION

Secure pedestal column to floor through mounting holes provided in base plate. Installer must furnish leveling materials, mounting hardware and anchors for connection of base plate to floor. Ensure unit is level and plumb before installing base cover and bolting telephone booth enclosure to pedestal. Service cables should be pulled through base center hole and left coiled inside column behind access panel. Hang each telephone booth enclosure onto a column hanger bracket. Bolt each booth to column with six (6) 1/4-20 bolts through holes provided in booth back wall into tapped holes provided in column. Set a telephone unit (by others) into each booth. Secure telephones (by others) onto back of units through any or all of seven (7) mounting holes into 1/4-20 tapped holes provided in concealed mounting plate. Pull wires up from column through telephone wiring hole and then hookup and close unit, making entire assembly theft and vandal resistant. For compliance with ADA Accessibility Guidelines unit is set to mount at 48" (1219) AFF to the coin slot centerline. **Unit top will be at 57" (1448) AFF and shelf bottom will be at 27" (686) AFF.**