



AMERICAN SPECIALTIES, INC.

441 Saw Mill River Road, Yonkers, NY 10701 (914) 476-9000
www.americanspecialties.com

MODEL No: 1550

ISSUED: 1-96

REVISED: 9-07

CURVED TELEPHONE ACCOMMODATION WITH FLUSH PANEL HOUSING AND WRITING SHELF

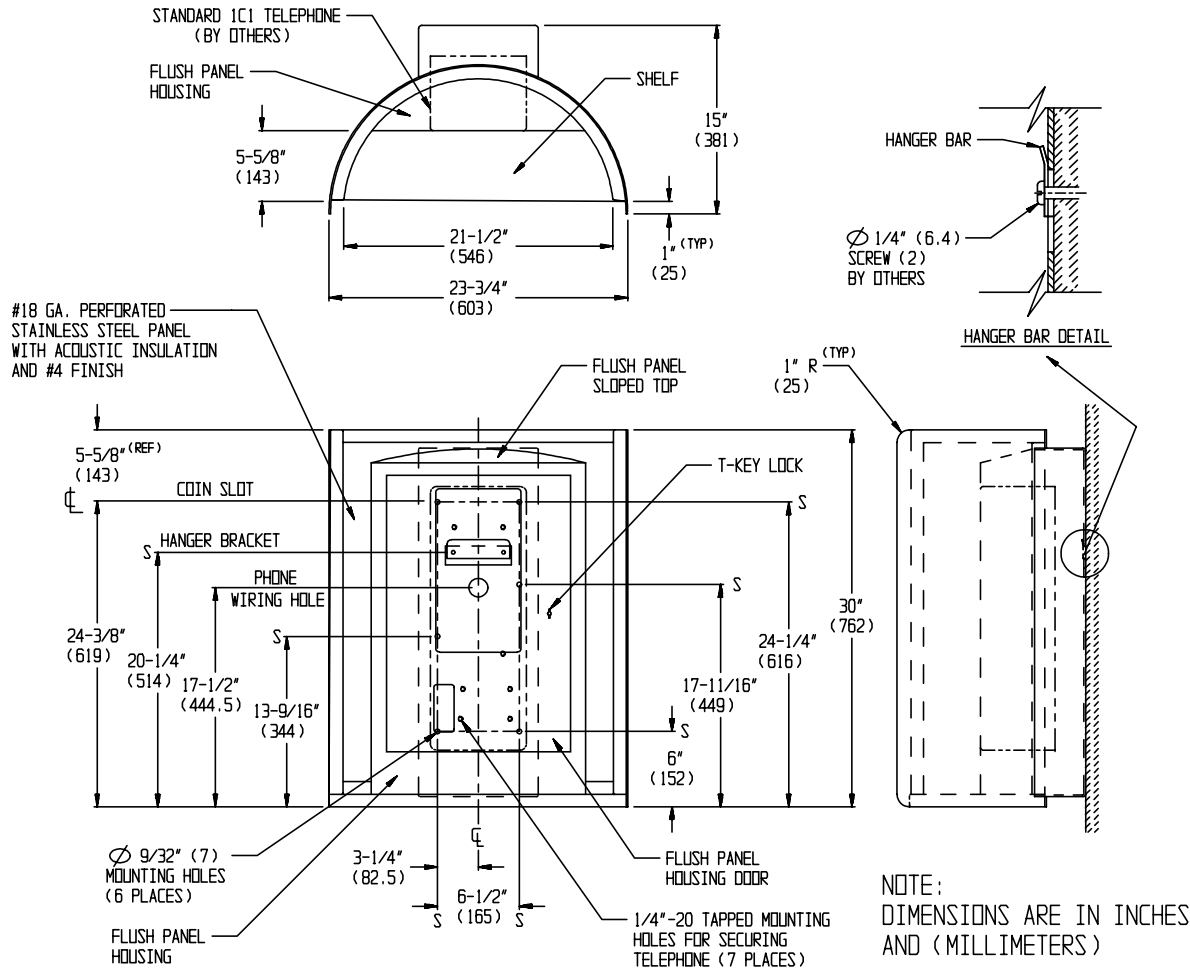

NOTE:
DIMENSIONS ARE IN INCHES
AND (MILLIMETERS)

SPECIFICATION

Curved Telephone Accommodation with Flush Panel Housing and Writing Shelf shall be fabricated of type 304 stainless steel alloy 18-8. One-piece surround shall be 1/8" (3.2) thick. Shelf shall be 16 gauge with removable closure plate on bottom held in place with pin-Torx® security button head screws. Enclosure shall have an 18 gauge perforated stainless steel interior 1" (25.4) thick with acoustic insulation filler inside for sound control. Flush panel housing, sloped top and door shall be 18 gauge. All exposed surfaces shall have a N° 4 satin finish. Unit is prepared to accept standard N° 1C1 surface mounted telephone (provided by others) onto mounting plate, which shall have a 1-1/2" diameter (Ø38) wiring hole and seven (7) 1/4-20-UNC-2B tapped holes for telephone mounting, behind concealed hinge door with T-key lock to provide panel phone look.

Curved Telephone Accommodation with Flush Panel Housing and Writing Shelf shall be Tellette Model N° 1550 as manufactured by American Specialties Inc., 441 Saw Mill River Road, Yonkers, NY 10701-4913

INSTALLATION

Secure hanger bracket to finished wall through two (2) mounting holes provided. Installer must furnish mounting hardware to suit wall construction. Hang assembled booth onto hanger bracket. Secure booth to finished wall through six (6) mounting holes provided in concealed mounting plate. Set telephone instrument (supplied by others) into back of unit recess and secure it to at least six (6) of the seven (7) 1/4-20 tapped mounting holes provided in concealed mounting plate, (with screws supplied by others) making total assembly theft-resistant. Close and lock panel door and retain T-key for future service. For compliance with ADA Accessibility Guidelines mount top of unit 53-5/8" (1362) maximum above finished floor (MAX AFF) for a coin slot centerline height of 48" (1219) MAX AFF. For general utility mount top of unit 70-5/8" (1794) AFF for a 65" (1651) AFF coin slot centerline height.

Accessory Specialties

AMERICAN DISPENSER

Desert Ray Products

WATROUS INC.