



AMERICAN SPECIALTIES, INC.
 441 Saw Mill River Road, NY 10701
 (914) 476.9000 • (914) 476.0688
 www.americanspecialties.com

MODEL №: 3800-U

ISSUED: 01/87

REVISED: 12/09

1-1/2" DIA (Ø38) CORRIDOR HANDRAIL SERIES WITH SNAP-ON FLANGE COVERS

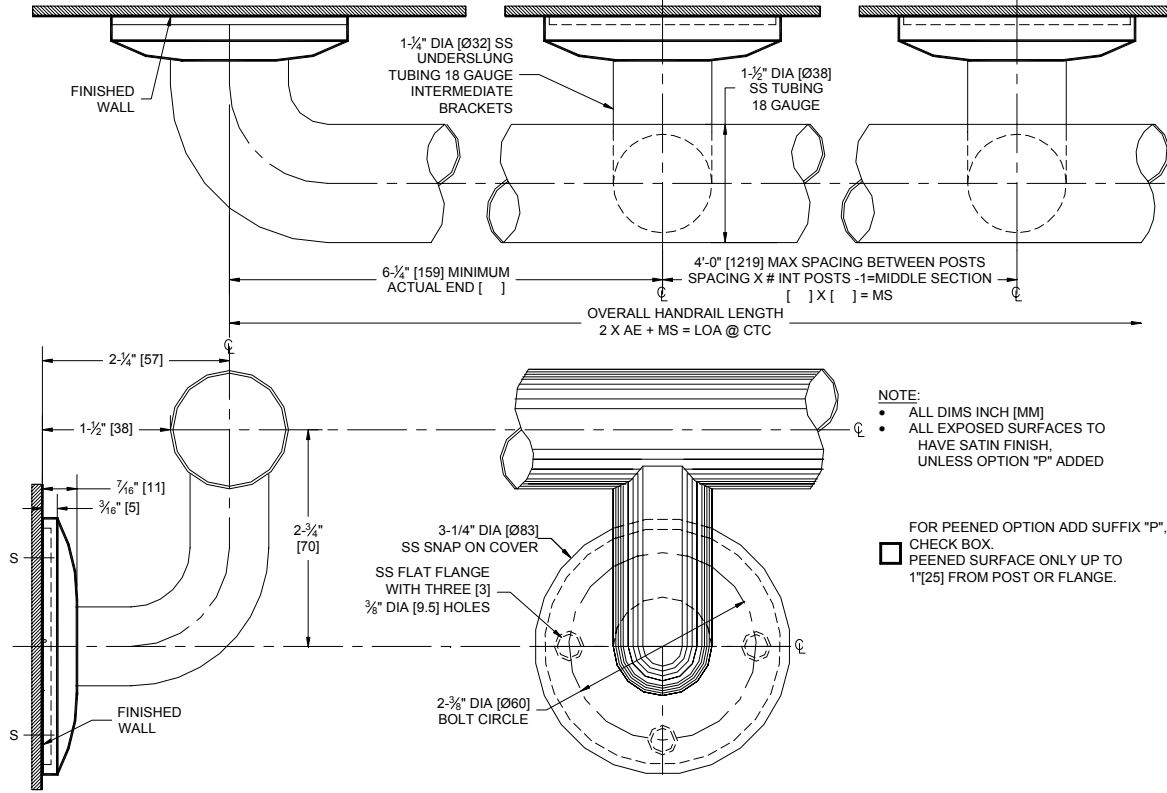

SPECIFICATION

Corridor Handrail with under slung Intermediate Supports and Snap-On Flange Covers for Concealed Mounting shall be type 304 stainless steel alloy 18-8. Rail tubing shall be 1-1/2" diameter (Ø38) x 18 gauge [0.048"] (1.2). Under slung intermediate supports tubing shall be 1-1/4" diameter (Ø32) x 18 gauge [0.048"] (1.2). Flange shall be 11 gauge 1/8" (3) thick and shall be Heliarc welded to tubing with a continuous concealed bead. Snap-on cover shall be 22 gauge [0.03"] (0.8). End flanges shall have two (2) 3/8" diameter (Ø9.5) mounting holes. Under slung intermediate supports flanges shall have three (3) 5/16" diameter (Ø8) mounting holes. All exposed surfaces shall have a satin finish and shall be protected during shipment with a plastic bag. For optional non-slip surface on areas indicated add suffix -P (peened).

1-1/2" Diameter (Ø38) Corridor Handrail with Under Slung Intermediate Supports and Snap-On Flange Covers for Concealed Mounting shall be Series № 3800-U of American Specialties, Inc., 441 Saw Mill River Road, Yonkers, New York 10701- 4913

STRENGTH

ASI Corridor Handrails are designed to meet and exceed ADA requirements as published in CABO/ANSI A117.1-2003 and CFR 28 Part 36, 1 July 1994, section 4.26.3 and FAB-ADA-ABA Regulations of 23 July 2004 Section 505. Mounting to the wall is a critical part of the system to meet this requirement. To withstand the shear, tension or pullout, and torsion loads generated by the maximum loading, the fastener system must be adequately sized.

INSTALLATION

Use grab bar as template to mark mounting holes locations and pre-drill holes. Install bar using two (2) № 10 self-tapping pan head screws and flat washers (by others) or other fastener system (by others) to suit conditions for each end flange and three (3) № 10 self-tapping flat head screws and flat washers (by others) or other fastener system (by others) to suit conditions for each under slung intermediate support flange. Appropriate anchoring and backing must be provided in accordance with local building codes or as specified on Architects Plans prior to wall finishing. For compliance with ADA Accessibility Guidelines install unit so that the top of the corridor handrail is 34" (864) minimum above finished floor (AFF) to 38" (965) maximum AFF. Anchors are available from ASI and must be specified separately for each corridor handrail style scheduled (see 3900 series).

Accessory Specialties

AMERICAN DISPENSER

Desert Ray Products

WITROLS, INC.