



AMERICAN SPECIALTIES, INC.

441 Saw Mill River Road, Yonkers, NY 10701 (914) 476-9000

MODEL No: 3935-1

ISSUED: 1-87

REVISED: 5-99

ANCHOR FOR 1" (25MM) THICK PARTITION WITH BACK-TO-BACK SNAP-ON FLANGE GRAB BARS

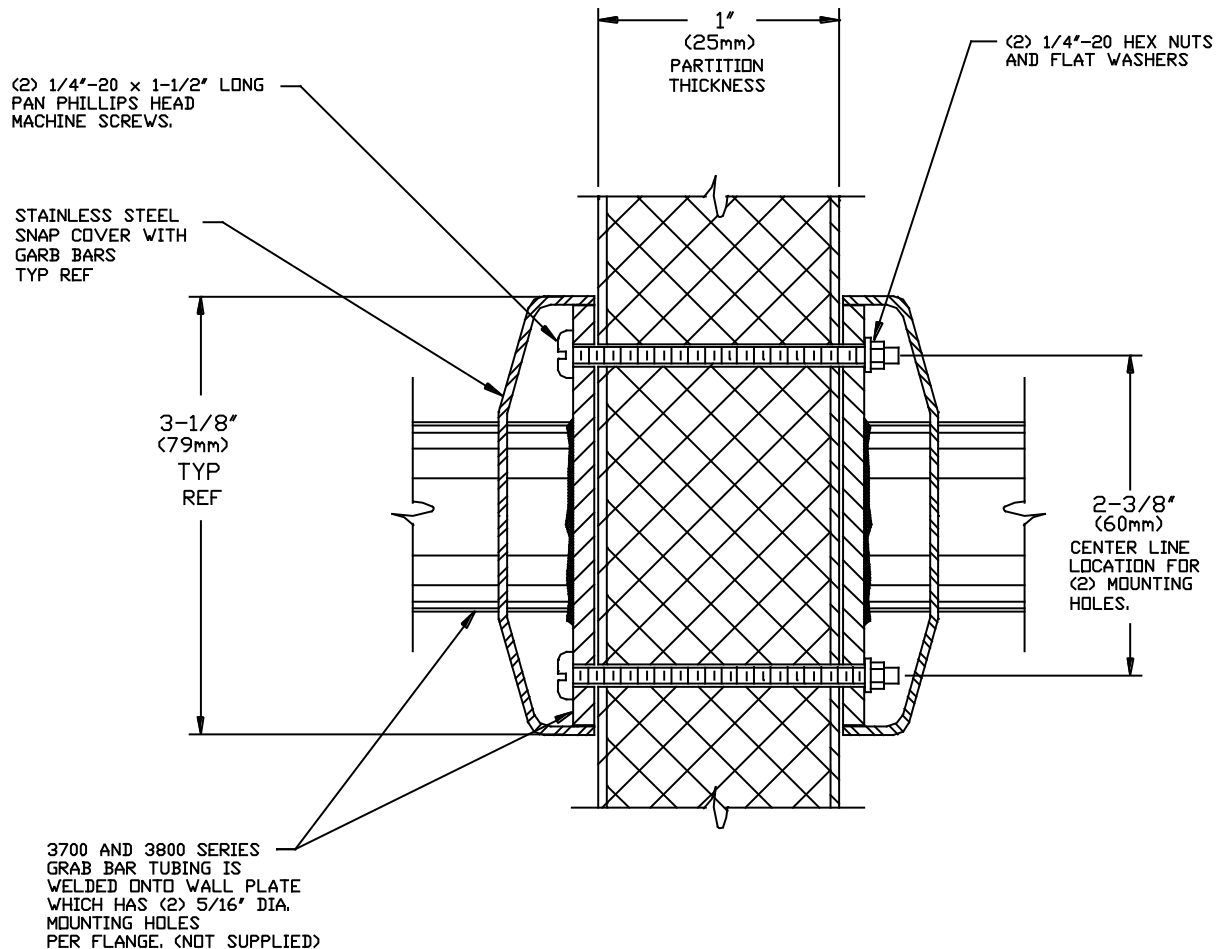

SPECIFICATION

Anchor for 1" (25mm) Thick Partition with Back-to-Back Snap-On Flange Grab Bars. Anchor kit shall contain two (2) 1/4-20 x 1-1/2" long machine screws with corresponding hex nuts and washers. Specify one (1) kit **per flange**.

Anchor shall be Model №3935-1 of American Specialties, Inc., 441 Saw Mill River Road, Yonkers, New York 10701- 4913

INSTALLATION

Place grab bar on partition at desired location and mark mounting hole locations. Drill 3/8" (10mm) dia. holes through the partition at marked locations. Place grab bars on both sides of partition and mount with 1/4-20 machine screws, washers and nuts (all provided) to complete installation. Refer to grab bar specification for correct procedure and strength data. For compliance with ADA Accessibility Guidelines mount unit so that centerline of horizontal grab bar is 33" (838mm) minimum to 36" (914mm) max. above finished floor (AFF).

Accessory Specialties

AMERICAN DISPENSER

Desert Ray Products

WATROUS INC.