



**AMERICAN SPECIALTIES, INC.**

441 Saw Mill River Road, Yonkers, NY 10701 (914) 476-9000

MODEL No: 3945-L/R

ISSUED: 1-87

REVISED: 4-99

**IN-WALL ANCHOR**

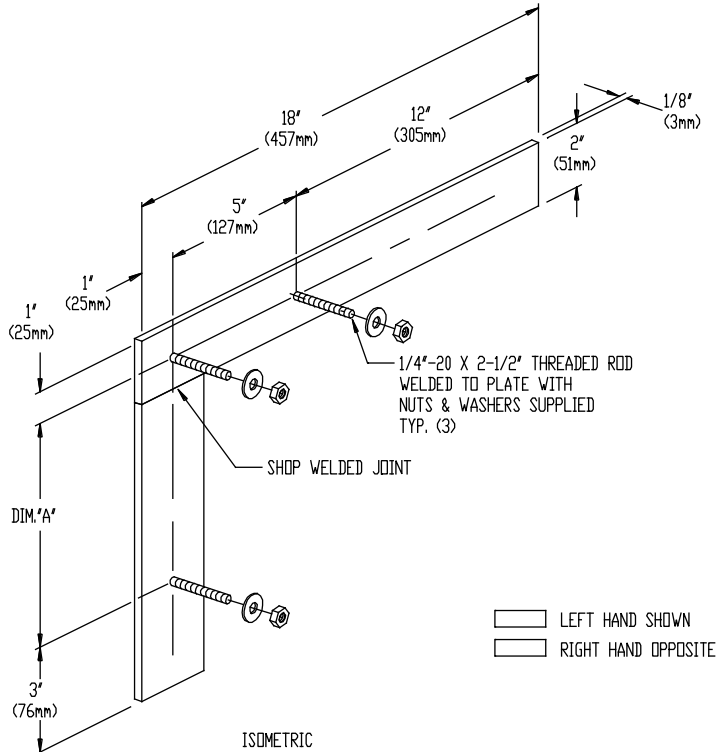

**SPECIFICATION**

In-Wall Anchor shall be suitable for securing one ASI Model N<sup>o</sup>19 Grab Bar in series 3000, 3100 or 3200 to a stud wall. Wall anchor shall be fabricated of two (2) steel plates 1/8" (3mm) thick x 2" (51mm) wide welded together in 'L' configuration and shall have lengths and stud placements as specified on fabrication drawing determined according to specifications of grab bar selected. Three (3) 1/4-20 threaded steel rods x 2-1/2" (64mm) long shall be welded to plates located at positions shown in drawing. Washers and nuts shall be supplied. Specify left-hand or right hand configuration. Wall anchors shall provide mounting point for three (3) support posts and shall be installed in rough wall (by others).

**In-Wall Anchor shall be Model 3945-R or L as manufactured by American Specialties, Inc., 441 Saw Mill River Road, Yonkers, New York 10701-4913**

**INSTALLATION**

For compliance with ADA Accessibility Guidelines mount grab bar so that horizontal centerline is 33" (838mm) minimum to 36" (914mm) maximum above finished floor. Drill anchor plate and screw, weld or wire plate to wall stud system in exact mounting location to suit field conditions before applying finish wall material. Take care not to bend threaded rods while constructing finished wall. Place tenon plates of grab bar on rods after finished wall is completed and fasten with washers and nuts. Mount grab bar to tenon plate with set screws provided to complete installation.

WALL ANCHORS ORDER SCHEDULE				
Qty/ Left-Hand	Qty/ Right-Hand	Anchor Model N <sup>o</sup>	Grab Bar Model N <sup>o</sup>	Dim 'A'

Accessory Specialties

AMERICAN DISPENSER

Desert Ray Products

WATROUS INC.