



AMERICAN SPECIALTIES, INC.

441 Saw Mill River Road, Yonkers, NY 10701 (914) 476-9000

MODEL No: 8251

ISSUED: 1-87

REVISED: 7-99

FRAMELESS STAINLESS STEEL MIRROR WITH MASONITE BACK

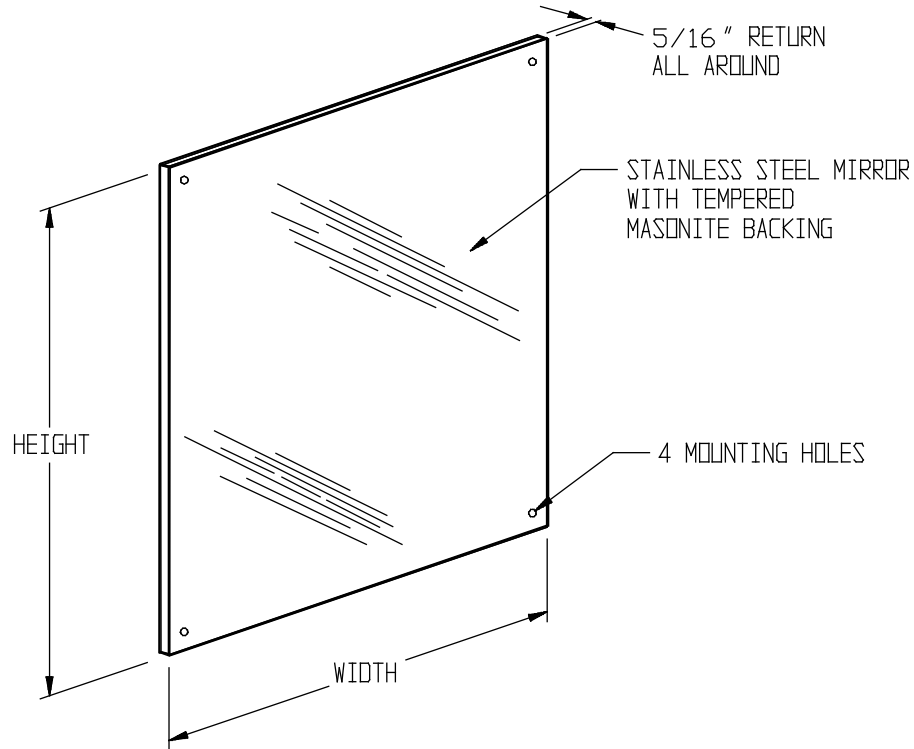

STANDARD STOCK SIZES					
Model N ^o	WIDTH	HEIGHT	Model N ^o	WIDTH	HEIGHT
8251-1620	16" (406mm)	20" (508mm)	8251-2430	24" (610mm)	30" (762mm)
8251-1624	16" (406mm)	24" (610mm)	8251-2436	24" (610mm)	36" (914mm)
8251-1824	18" (457mm)	24" (610mm)	8251-4824	48" (1219mm)	24" (610mm)
8251-1830	18" (457mm)	30" (762mm)			

SPECIFICATION

Frameless Stainless Steel Mirror with Masonite Back shall be fabricated of type 430 bright annealed stainless steel, 22 gauge (.8mm). Backing shall be 1/4" (6mm) thick tempered water-resistant masonite. Unit shall have 5/16" (8mm) returns to wall all around. Unit shall be provided with four (4) 7/32" (5.5mm) dia. mounting holes.

Frameless Stainless Steel Mirror with Masonite Back shall be Model N^o 8251- _____ as manufactured by American Specialties, Inc., 441 Saw Mill River Road, Yonkers, New York 10701-4913

INSTALLATION

Surface mount unit to wall using hardware supplied by installer through four mounting holes provided. For compliance with ADA Accessibility Guidelines install unit with bottom edge of reflecting surface no higher than 40" (1016mm) maximum above finished floor.

DESIGNERS NOTE

The reflective quality of a stainless steel mirror is not as true as plate glass. It is not recommended that a mirror of this type be made larger than 48" W x 24"H (1219mm x 610mm) because image quality (distortion) degrades with increased surface size.

Accessory Specialties

AMERICAN DISPENSER

Desert Ray Products

WATROUS INC.