



**AMERICAN SPECIALTIES, INC.**  
 441 Saw Mill River Road, NY 10701  
 (914) 476.9000 • (914) 476.0688  
 www.americanspecialties.com

**MODEL №: 94696A-9**

**ISSUED: 01/06**

**REVISED: 10/09**

**SURFACE MOUNTED AUTOMATIC ROLL PAPER TOWEL DISPENSER AND WASTE RECEPTACLE**

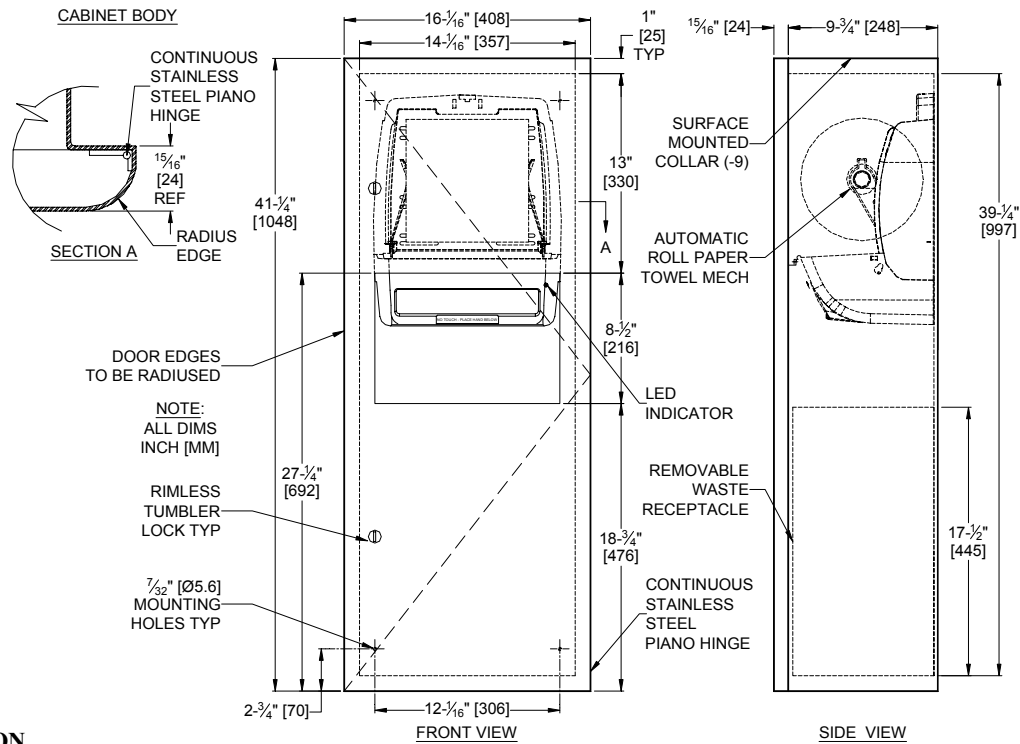

**SPECIFICATION**

Surface Mounted Automatic Roll Paper Towel Dispenser and Waste Receptacle shall hold and dispense one 8" diameter (Ø203) x 8" wide (203) standard towel roll up to 800 ft. (244m) long and one 8" wide (203) stub roll up to 4" diameter (Ø102) and shall have a waste capacity of 10 gallons (38 liters). Automatic Touchless Roll Towel Dispenser shall be powered by four (4) D-size batteries (not supplied) and shall operate automatically to activate towel dispensing when hands are placed in sensor zone. At each activation unit shall feed out a length of towel selected by owner by setting length, delay and paper saver switches. Unit shall have an internal towel cut-off bar. Full-face door, cabinet and waste receptacle shall be fabricated of type 304 stainless steel alloy 18-8. All exposed surfaces shall have satin finish and shall be protected during shipment with PVC film easily removable after installation. Cabinet and frame shall be fabricated of 20 gauge stainless steel with 1" (25.4) wide perimeter trim to lay flat against wall. Full-face door shall be 16 gauge and shall be free of miters, welding or open seams with 3/4" (19) radiused vertical edges and 15/16" (24) square horizontal returns to collar. Towel dispensing opening shall be fully deburred and have a full return and formed sill at top edge for user safety. Door shall be attached to the edge of unit with a concealed full length 3/16" diameter (Ø4.8) heavy duty stainless steel multi-staked piano hinge and shall be held closed with two (2) flush rimless tumbler locks keyed alike to other ASI washroom equipment. Unit back plate for mechanism shall be fabricated of 18 gauge. Interior waste receptacle shall be fabricated of stainless steel and shall have a welded on finger pull for ease of service removal and maintenance safety. Structural assembly of all components shall be of welded construction. Cabinet shall have no exposed fastening devices or spot-welded seams. Collar is supplied for surface mounting conversion.

**Surface Mounted Automatic Roll Paper Towel Dispenser and Waste receptacle shall be Model № 94696A-9 as manufactured by American Specialties, Inc., 441 Saw Mill River Road, Yonkers, New York 10701-4913**

**INSTALLATION**

Surface mount unit on wall with four (4) № 10 self-tapping screws (supplied by others) through concealed mounting holes provided. For compliance with ICC/ANSI A-117.1-2003 and ADA Accessibility Guidelines, install unit so that top edge of towel dispenser opening is 48" (1219) maximum above finished floor (MAX AFF) only if clear floor reach access is provided. Be advised that local codes may require mounting so that top of towel dispenser opening is 40" (1016) MAX AFF (e.g. California UBC/Title 24). For general utility install unit with centerline of towel dispenser opening between 49" and 56" (1245 to 1422) AFF.

**OPERATION**

Towels are dispensed one at a time automatically when hands are placed in sensor zone until supply is depleted. Owner predetermines length of towel dispensed by making selections on three (3) three-position switches for length, delay, and economy. Unit may be re-loaded with a full roll to automatically start when finished with an existing partial roll and will continue to feed properly when reloaded with a full roll and partial roll is transferred to stub roll position. Refill dispenser by unlocking door and replacing towel roll for an empty or partially empty unit. Dispenser supply is replenished, batteries are replaced and waste receptacle is emptied manually on cycles determined by maintenance needs. LED indicates sensing and battery condition. Locking door prevents unauthorized access and roll removal.

**Accessory Specialties**

**AMERICAN DISPENSER**

**Desert Ray Products**

**WATROUS, INC.**