



AMERICAN SPECIALTIES, INC.

441 Saw Mill River Road, Yonkers, NY 10701 (914) 476-9000

MODEL No: 045224

ISSUED: 1-87

REVISED: 10-04

RECESSED ROLL PAPER TOWEL DISPENSER

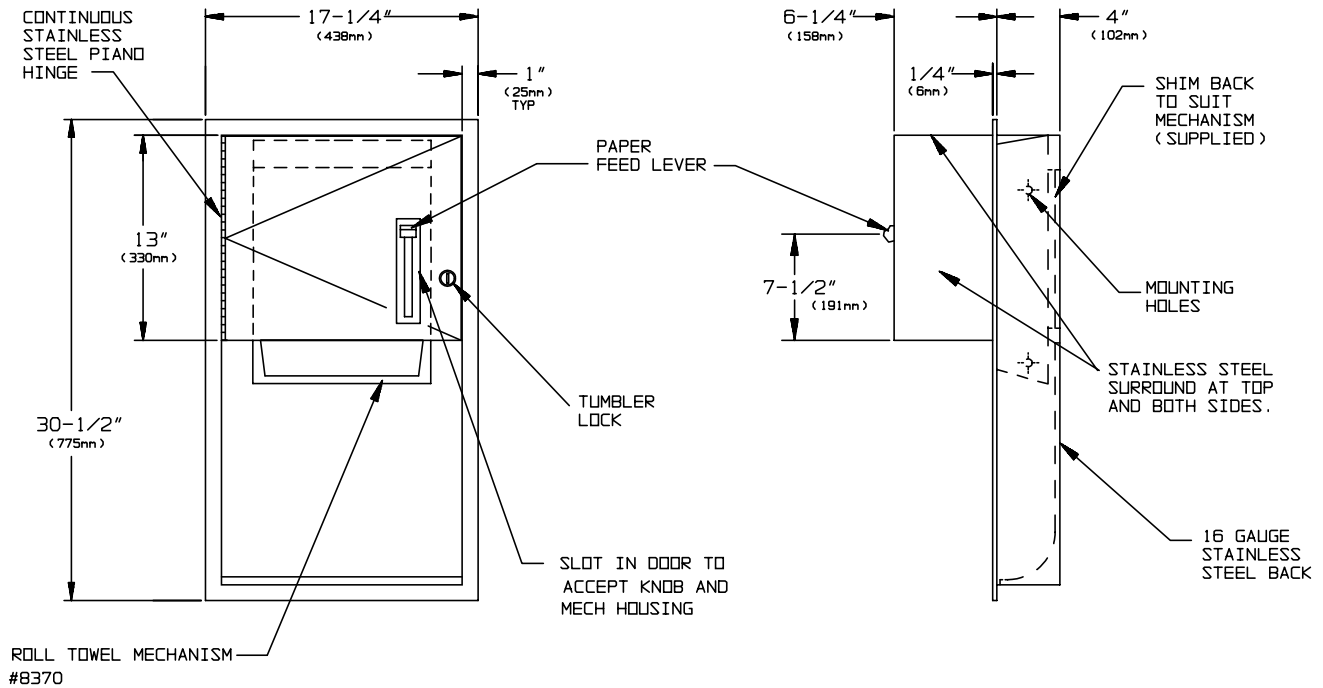

SPECIFICATION

Recessed Roll Paper Towel Dispenser shall hold and dispense one 8" or 9" (203mm or 229mm) wide standard towel roll up to 800 ft. (244m) long and one stub roll up to 4" (102mm) diameter. Unit shall be fabricated of alloy 18-8 stainless steel type 304, 22 gauge; rear panel of unit shall be 18 gauge. A dispensing mechanism shall be supplied. Door shall be attached to cabinet at side with a full length 3/16" (5mm) multi staked piano hinge and shall be held closed with tumbler lock keyed alike to other ASI washroom equipment. Face trim shall be 1" (25mm) wide formed from one piece with no miters, welding or open seams and shall have a 1/4" (6mm) square return to wall. Structural assembly of all components shall be of welded construction. All exposed surfaces shall have a N° 4 satin finish and shall be protected with a PVC film easily removable after installation.

Recessed Roll Paper Towel Dispenser shall be Model N° 045224 as manufactured by American Specialties, Inc., 441 Saw Mill River Road, Yonkers, New York 10701-4913

INSTALLATION

Unit is mounted in wall recess using N° 10 self-tapping screws (by others) through concealed mounting holes provided. For compliance with ADA Accessibility Guidelines, unit should be installed so that towel dispenser lever is 39-3/4" (1010mm) above finished floor (AFF). Note that top of RWO is 3/4" (19mm) below top of unit.

Rough Wall Opening required is.....15-3/4"W. x 29"H. x 4"D. (400mm x 737mm x 102mm)

OPERATION

Towels are fed by lever action until supply is depleted. Unit may be reloaded with a full roll to automatically start when finished with an existing partial (stub) roll.

Accessory Specialties

AMERICAN DISPENSER

Desert Ray Products

WATROUS INC.