



AMERICAN SPECIALTIES, INC.

441 Saw Mill River Road, Yonkers, NY 10701 (914) 476-9000

MODEL No: 046924

ISSUED: 1-87

REVISED: 10-04

RECESSED ROLL PAPER TOWEL DISPENSER AND WASTE RECEPTACLE

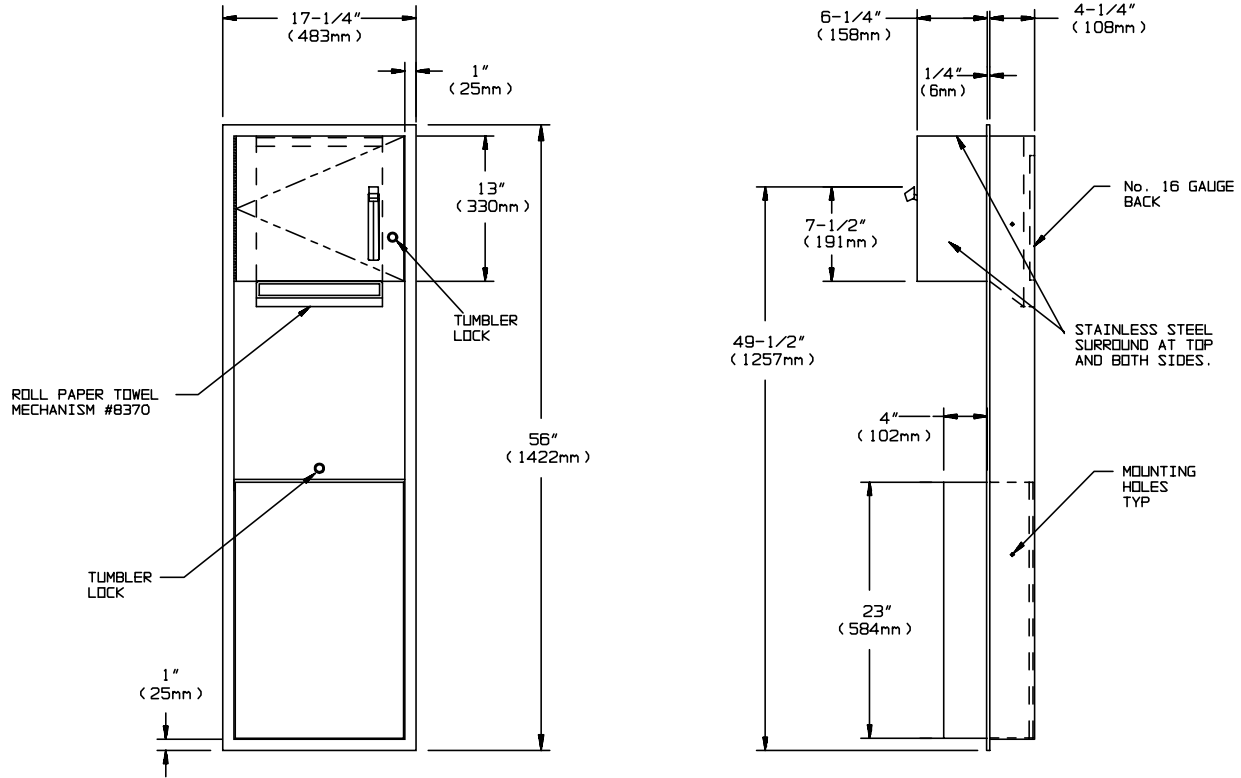

FRONT VIEW

SIDE VIEW

SPECIFICATION

Recessed Roll Paper Towel Dispenser and Waste Receptacle shall hold and dispense one 8" or 9" wide standard towel roll up to 800 ft. (244m) long and one stub roll up to 4" (102mm) diameter and shall have a waste capacity of 12 gal. (45.4 liters). Unit frame, waste container and cabinet shall be fabricated of alloy 18-8 stainless steel, type 304, 22 gauge; towel dispenser door shall be same grade 18 gauge; unit back plate for mechanism shall be fabricated of 18 gauge; all exposed surfaces shall have N° 4 satin finish protected by a plastic PVC film easily removed after installation. Towel dispensing slot shall be smooth and burr-free for snag-free dispensing and user safety. Door shall be attached to cabinet at side with a full length 3/16" dia. stainless steel multi-staked piano hinge and be held closed with tumbler lock keyed alike to other ASI washroom equipment. Waste container shall have hemmed edges for safety and shall be retained by a tumbler lock keyed alike. Face trim shall be 1" (25.4mm) wide formed from one piece with no miters, welding or open seams and have 1/4" (6.35mm) square return to wall. Structural assembly of all components shall be of welded construction. Cabinet shall have no exposed fastening devices or spot welded seams.

Recess Mounted Roll Paper Towel Dispenser and Waste Receptacle shall be Model N°046924 as manufactured by American Specialties, Inc., 441 Saw Mill River Road, Yonkers, New York 10701-4913.

INSTALLATION

Unit is mounted in wall recess using N° 10 self tapping screws (by others) through concealed mounting holes provided. For compliance with ADA Accessibility Guidelines, unit should be installed so that towel dispenser lever is 54" (1372mm) maximum above finished floor (AFF) if clear floor side reach access is provided. Note that top of RWO is 3/4" (19mm) below top of unit

Rough Wall Opening (RWO) required is..... 15-3/4"W x 54-1/2"H x 4"D minimum (400mm x 1384mm x 102mm)

OPERATION

Towels are fed by lever action until supply is depleted. Towel feed length is adjustable for economy by pin (supplied) limiting of lever stroke length. Unit may be reloaded with a full roll to automatically start when finished with an existing partial roll. Waste container is emptied manually on cycle determined by maintenance needs.

Accessory Specialties

AMERICAN DISPENSER

Desert Ray Products

WATROUS INC.